

LONESTAR EMERGENCY GROUP, LLC

HOUSTON, TX

SO.145309 / Q106042
PUMPER
TYPHOON 4X2 CHASSIS

2000 GPM HALE QMAX PUMP		HOSE LOAD:	
1000 GALLON WATER TANK		NFPA CAPACITY	
30 GALLON INTEGRAL CLASS "A" FOAM			
COMPT.	OPENING	INTERIOR DIMENSION	
L1	40W 59H	42W 3H 12D UPPER	
		42W 56H 26D LOWER	
L2	54W 25H	56W 3H 12D UPPER	
		56W 22H 26D LOWER	
L3	54W 59H	42W 3H 12D FRONT UPPER	
		42W 56H 26D FRONT LOWER	
		14W 3H 10D REAR UPPER	
		14W 56H 24D REAR LOWER	
R1	40W 59H	42W 25H 12D UPPER	
R2	54W 25H	42W 30H 26D LOWER	
R3	54W 59H	56W 25H 12D FRONT UPPER	
		42W 30H 26D FRONT LOWER	
		14W 25H 10D REAR UPPER	
		14W 30H 24D REAR LOWER	
B1	36W 51H	38W 51H 26D	

THIS DRAWING IS FOR REFERENCE PURPOSES. ALL DIMENSIONS ARE SUBJECT TO MINOR VARIATIONS DUE TO MANUFACTURING PROCESSES.

(FOR INTERNAL SALES PURPOSES ONLY)

DEALER APPROVAL _____ DATE _____ AS IS
CUSTOMER APPROVAL _____ DATE _____ WITH REVISIONS

HOSEBED HEIGHT:
(FOR REFERENCE ONLY)
TO TAILBOARD: 74"
TO GROUND: 98±2"

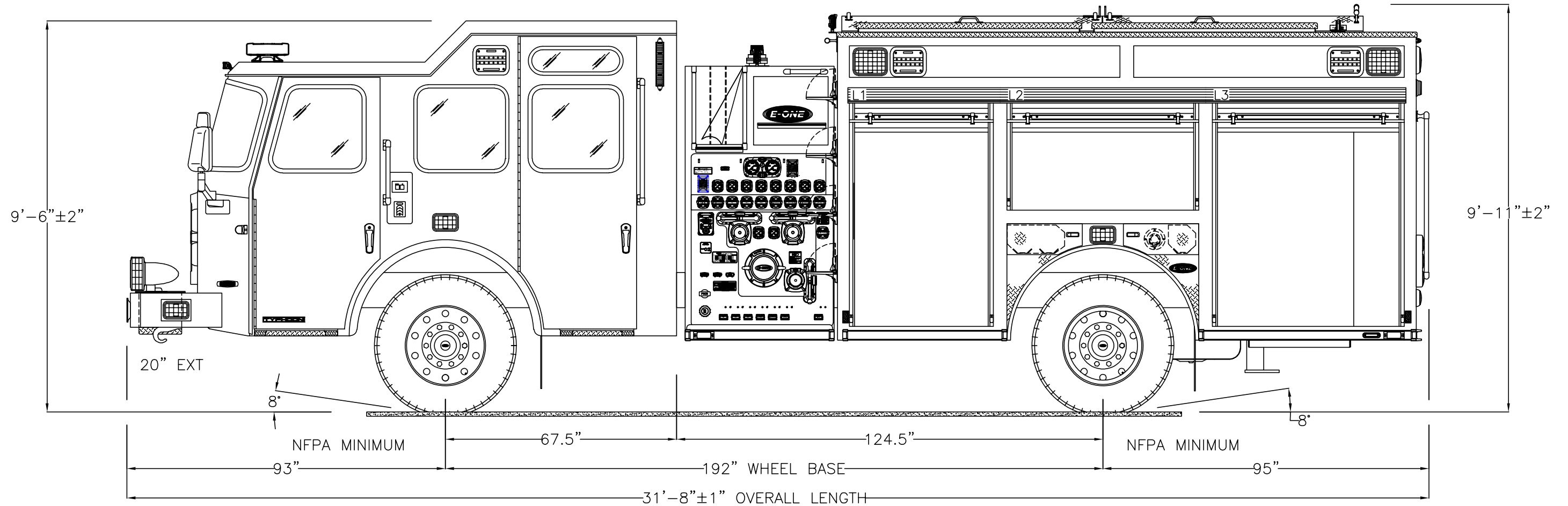
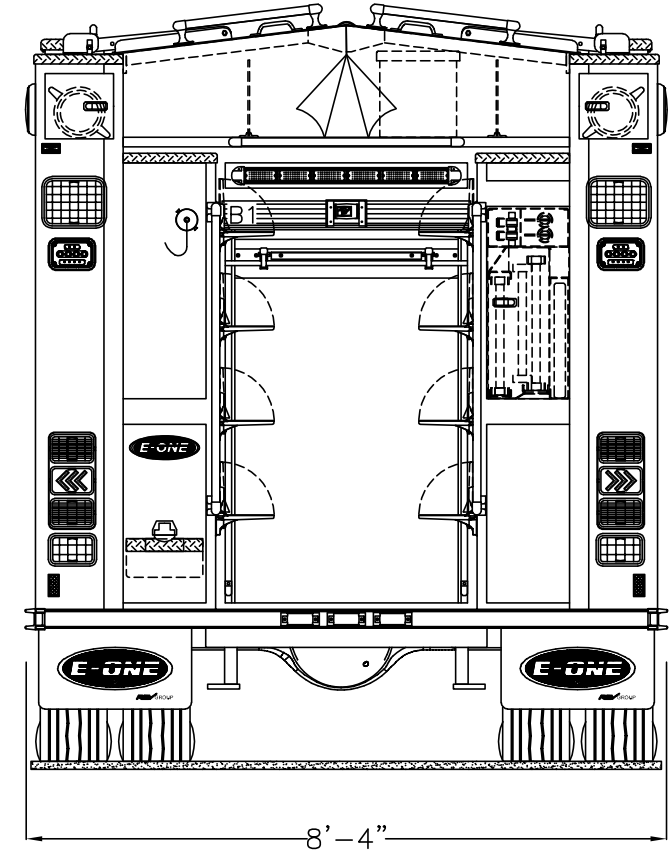
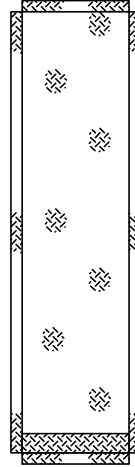

DADKINS	A.3	ORDER RELEASE	2022-MAY-25	DGALLAGHER
DRAWN BY	REV	DESCRIPTION	DATE	APPROVED
		APPROVAL REVISIONS		SHEET 1 OF 2

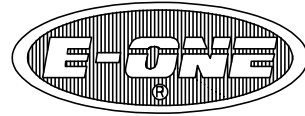

LONESTAR EMERGENCY GROUP, LLC
HOUSTON, TX
SO.145309 / Q106042
PUMPER
TYPHOON 4X2 CHASSIS

THIS DRAWING IS FOR REFERENCE PURPOSES. ALL DIMENSIONS ARE SUBJECT TO MINOR VARIATIONS DUE TO MANUFACTURING PROCESSES.

(FOR INTERNAL SALES PURPOSES ONLY)

DEALER APPROVAL _____ DATE _____ AS IS
 CUSTOMER APPROVAL _____ DATE _____ WITH REVISIONS

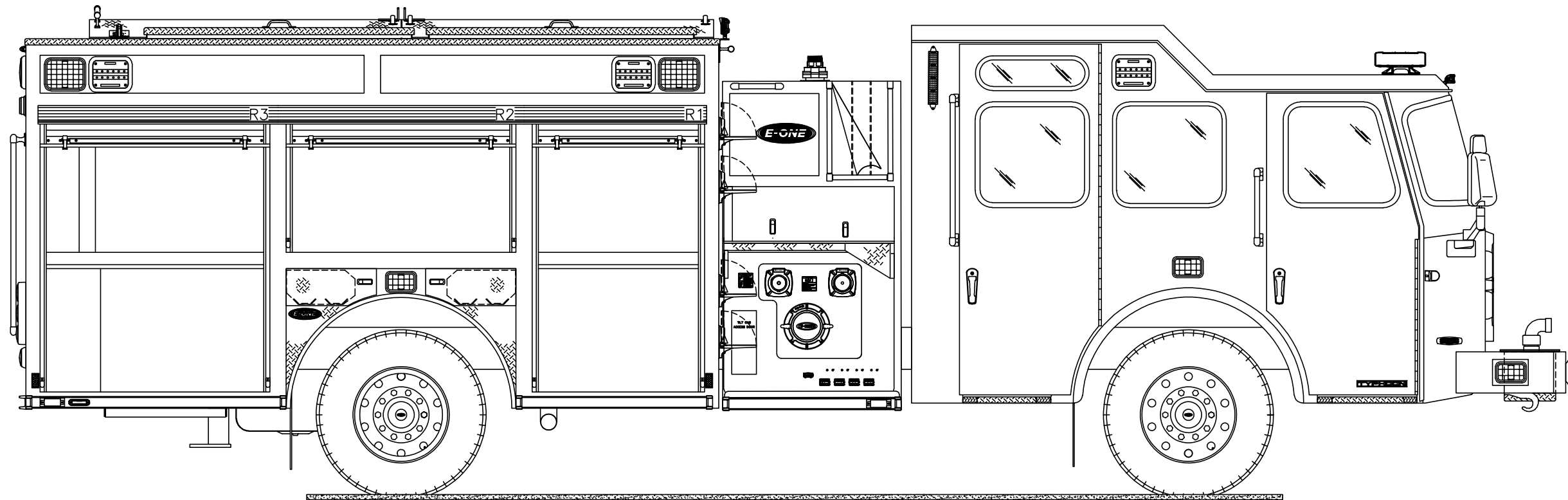
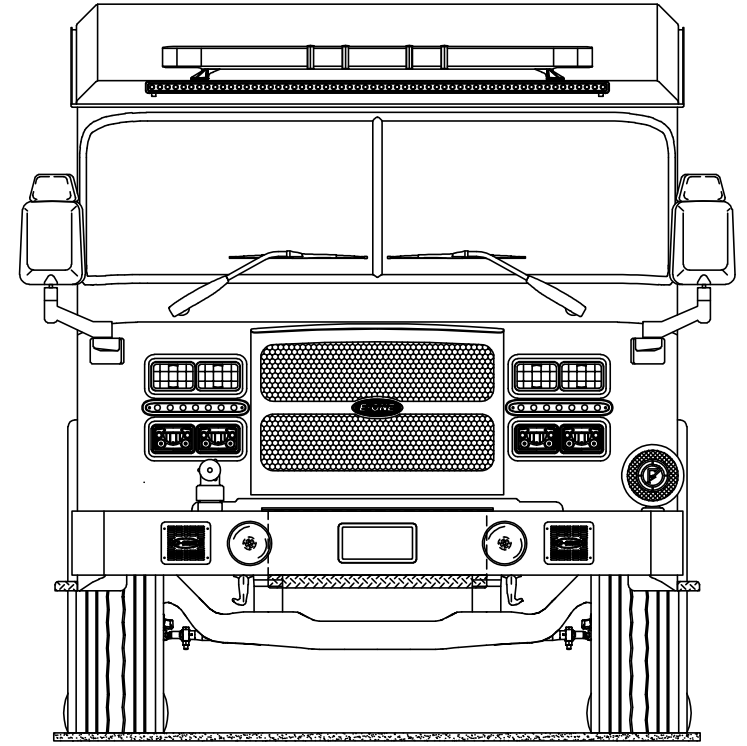

DADKINS	A.3	ORDER RELEASE	2022-MAY-25	DGALLAGHER
DRAWN BY	REV	DESCRIPTION	DATE	APPROVED
APPROVAL REVISIONS				SHEET 2 OF 2